



54, Annapurna Industrial Estate, Tilak Road,  
Ghatkopar (E), Mumbai - 400 077 India  
Tel: +91-22-21029911  
E-mail: sales@excellaelectronics.com



## SENSOR

### AC INDUCTIVE SENSOR

| Type                             | AC 2 Wire Proximity Sensor.                                     |                         |                         |
|----------------------------------|---|-------------------------|-------------------------|
| Dimension                        | M12   | M18                     | M30                     |
|                                  | Connector /Direct Cable   | Connector /Direct Cable | Connector /Direct Cable |
|                                  | Flush / Non Flush   | Flush / Non Flush       | Flush / Non Flush       |
| Sensing Distance (mm)            | 2 / 4   | 5/ 8                    | 10/15                   |
| Hystersis                        | +/- 10% of Detecting Distance                                   |                         |                         |
| Logic                            | NO or NC  |                         |                         |
| Operating Voltage                | 90 - 300 VAC  |                         |                         |
| I Max                            | 500 mA  |                         |                         |
| Response Frequency               | 25Hz  |                         |                         |
| Current Consumption              | 15mA  |                         |                         |
| Leakage Current                  | < 0.7mA   |                         |                         |
| Voltage Drop                     | < 10 V  |                         |                         |
| Cable Length/ Wiring Connections | PVC Cable: 2 Core, 3mtrs ( Brown :+Ve, Blue :-Ve )              |                         |                         |
| Indicators                       | Operation Indicators ( RED or GREEN LED)                        |                         |                         |
| Ambient Temperature              | -10 to +70 Deg. C   |                         |                         |
| Storage Temperature              | -20 to +80 Deg. C   |                         |                         |
| Environmental Protection         | IP 54 / IP 65 / IP 67 ( Normally IP 54 )                        |                         |                         |
| Weight                           | Approx:80g  | Approx:110g             | Approx:205g             |
| Materails                        | Case & Two fixing Nuts : Stainless Steel or Nickel Plated Brass |                         |                         |



## SENSOR

### SENSOR DIMENSIONS

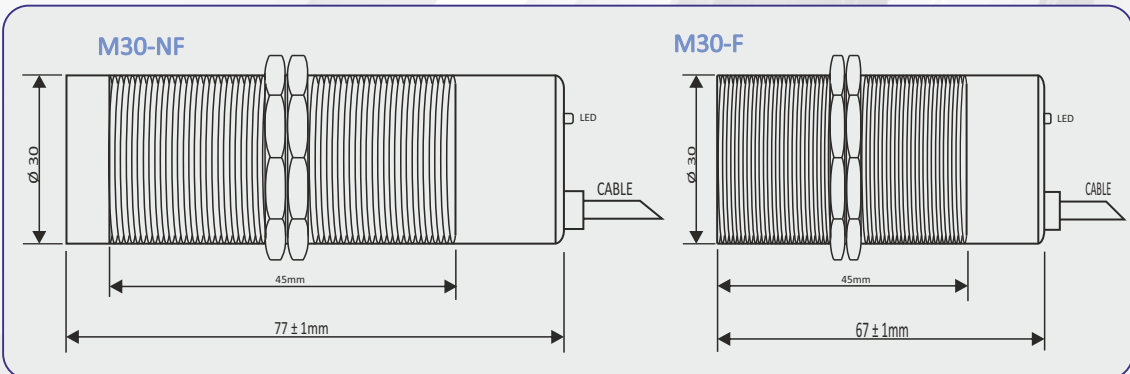
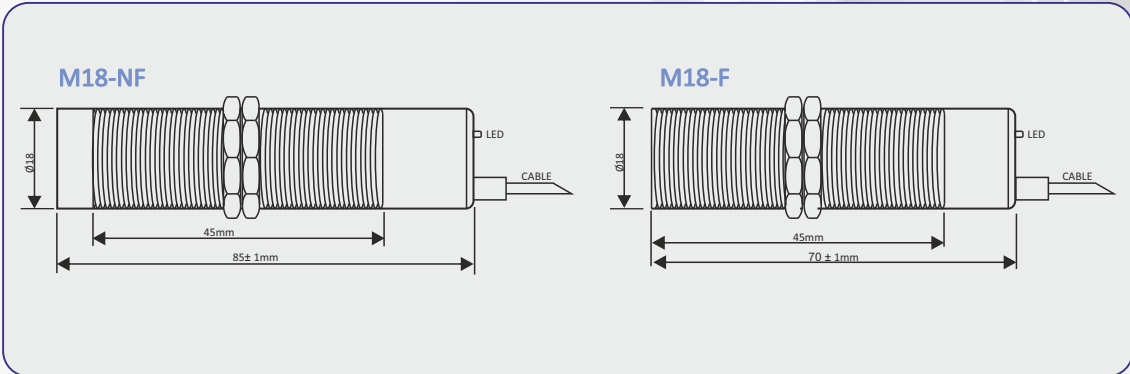
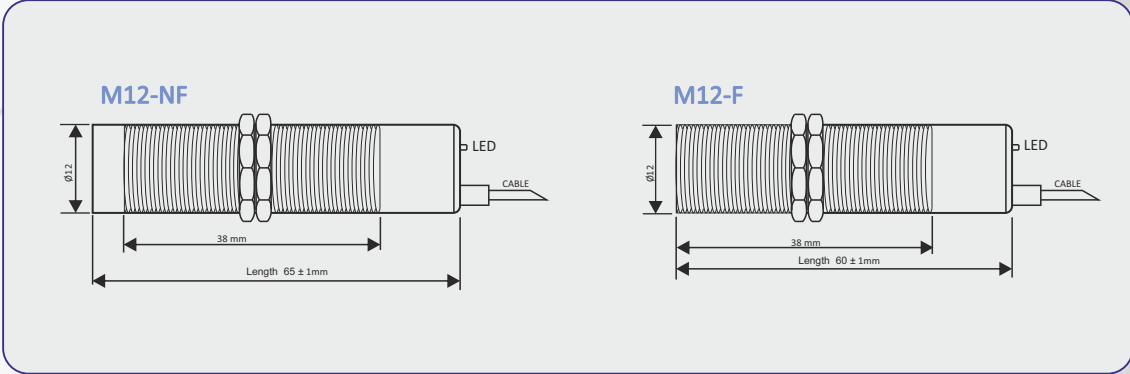

### WIRING DIAGRAM:

